

Raccorderia in polipropilene

Polypropylene fittings

Raccords en polypropylène

CARATTERISTICHE TECNICHE COMUNI ALLA RACCORDERIA GEOLINE

La raccorderia GEOLINE è realizzata in polipropilene (altri materiali a richiesta) e guarnizioni in EPDM (Viton® a richiesta).
I girelli, le ghiere e i tappi GEOLINE sono realizzati in polipropilene rinforzato con fibra di vetro (altri materiali a richiesta) e guarnizioni in EPDM (Viton® a richiesta).
Le filettature GEOLINE sono conformi alle normative BSP (altre filettature a richiesta).

Raccordi
Riduzioni
Bocchettoni di scarico
Accoppiatori
Raccorderia varia
Guarnizioni

TECHNICAL FEATURES FOR GEOLINE FITTINGS

GEOLINE fittings are made of polypropylene (other materials on demand), with EPDM gaskets (Viton® on demand).
GEOLINE fly nuts, back nuts and cups are made of fiberglass reinforced polypropylene (other materials on demand), with EPDM gaskets (Viton® on demand).
GEOLINE threads comply with BSP standards (other threads on demand).

Fittings
Reducers
Tank outlets
Cam lever couplers
Various fittings
Gaskets

CARACTERISTIQUES TECHNIQUES COMMUNES AUX RACCORDS GEOLINE

Tous les raccords GEOLINE sont en polypropylène (autres matériaux sur demande), et les joints en EPDM (Viton® sur demande).
Les écrous, embouts et bouchons GEOLINE sont en polypropylène renforcé par fibres de verre (autres matériaux sur demande), avec les joints en EPDM (Viton® sur demande).
Les filetages GEOLINE sont conformes aux normes BSP (autres filetages sur demande).

Raccords
Réductions
Goulotte vidange
Raccord rapides à cammes
Raccords divers
Joints

- Raccorderia in polipropilene
- Polypropylene fittings
- Raccords en polypropylène

Raccordo portagomma diritto per girello

Hosetail for fly nut

Raccord droit pour écrou

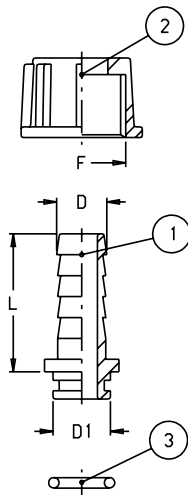

Part No.			F	D mm	D1 mm	L mm	Pack
1	2	3					
8002150	8040151	G00001002	1/2"	11	13,7	39,5	25
8002151	8040152	G00001002		13	13,7	39,5	25
8002200	8040201	G00001012	3/4"	13	17,5	44	25
8002201	8040201	G00001012		15	17,5	44	25
8002202	8040202	G00001012		19	17,5	49	25
8002250	8040251	G00001018		13	24,5	49	25
8002251	8040251	G00001018	1"	15	24,5	50	25
8002252	8040251	G00001018		19	24,5	51	25
8002253	8040251	G00001018		22	24,5	51	25
8002254	8040251	G00001018		25	24,5	51	25
8002300	8040301	G00001022	1 1/4"	22	31,5	53	25
8002301	8040301	G00001022		25	31,5	53	25
8002302	8040301	G00001022		30	31,5	60	25
8002303	8040301	G00001022		32	31,5	63	25
8002356	8040351	G00001028	1 1/2"	15	37,5	38	25
8002350	8040351	G00001028		25	37,5	55	25
8002351	8040351	G00001028		30	37,5	62	25
8002352	8040351	G00001028		32	37,5	65	25
8002353	8040351	G00001028	2"	35	37,5	70	25
8002354	8040351	G00001028		38	37,5	72	25
8002355	8040351	G00001028		40	37,5	72	25
8002400	8040401	G00001030		40	47	78	10
8002401	8040401	G00001030	2"	45	47	81	10
8002402	8040401	G00001030		50	47	84	10

Raccordo portagomma curvo 90° per girello

90° Hosetail for fly nut

Raccord coudé à 90° pour écrou

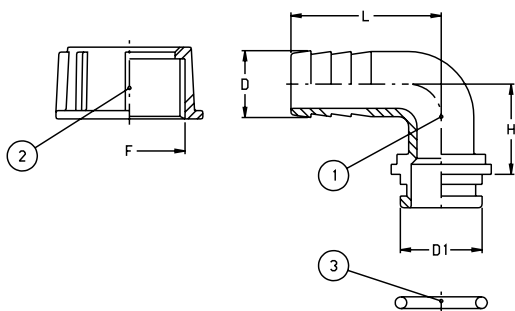

Part No.			F	D mm	D1 mm	L mm	Pack
1	2	3					
8012200	8040202	G00001012	3/4"	13	17,5	37	25
8012201	8040202	G00001012		15	17,5	40	25
8012203	8040202	G00001012		19	17,5	45	25
8012250	8040251	G00001018	1"	15	24,5	40	25
8012251	8040251	G00001018		19	24,5	45	25
8012252	8040251	G00001018		25	24,5	53	25
8012300	8040301	G00001022	1 1/4"	22	31,5	53	25
8012301	8040301	G00001022		25	31,5	53	25
8012302	8040301	G00001022		30	31,5	60	25
8012303	8040301	G00001022		32	31,5	60	25
8012350	8040351	G00001028	1 1/2"	25	37,5	53	25
8012351	8040351	G00001028		30	37,5	60	25
8012352	8040351	G00001028		32	37,5	60	25
8012353	8040351	G00001028		35	37,5	80	25
8012354	8040351	G00001028	2"	38	37,5	85	25
8012355	8040351	G00001028		40	37,5	85	25
8012400	8040401	G00001030		40	47	85	10
8012401	8040401	G00001030	2"	45	47	90	10
8012402	8040401	G00001030		50	47	90	10
8012403	8040401	G00001030		52	47	90	10

Raccordo portagomma diritto con battuta piana per girello. Flat seat hosetail for fly nut.

Raccord droit avec siège plat pour écrou.

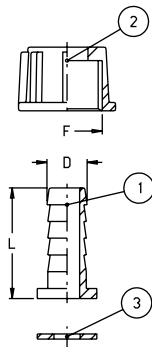

Part No.			F	D mm	L mm	Pack
1	2	3				
8003100	8040101	G00002000	3/8"	11	37	25
8003150	8040152	G00002002	1/2"	11	37	25
8003151	8040152	G00002002		13	37	25
8003200	8040201	G00002004	3/4"	15	36	25
8003201	8040201	G00002004		19	41	25
8003250	8040251	G00002006	1"	25	41	25
8003300	8040301	G00002010	1 1/4"	30	49	25

Raccordo portagomma curvo 90° con battuta piana per girello. 90° flat seat hosetail for fly nut.

Raccord coudé a 90° avec siège plat pour écrou.

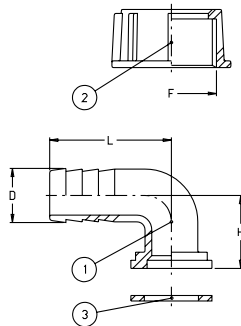

Part No.			F	D mm	H mm	L mm	Pack
1	2	3					
8013150	8040152	G00002002	1/2"	11	28,5	33	25
8013200	8040201	G00002004	3/4"	13	31,5	36	25
8013201	8040202	G00002004		19	33	45	25
8013250	8040251	G00002006	1"	25	36,5	53	25
8013300	8040301	G00002010	1 1/4"	30	44	60	25

Raccordo portagomma curvo 45° per girello. 45° hosetail for fly nut.

Raccord coudé a 45° pour écrou.

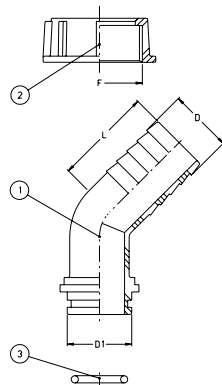

Part No.			F	D mm	D1 mm	L mm	Pack
1	2	3					
8015300	8040301	G00001022	1 1/4"	30	31,5	48	25
8015350	8040351	G00001028	1 1/2"	30	37,5	48	25
8015351	8040351	G00001028		35	37,5	48	25
8015352	8040351	G00001028	2"	40	37,5	51	25
8015400	8040401	G00001030		40	47	60	25

Raccordo portagomma curvo 45° con filetto maschio. 45° male threaded hosetail.

Raccord porte-tuyau coudé a 45° filetage mâle.

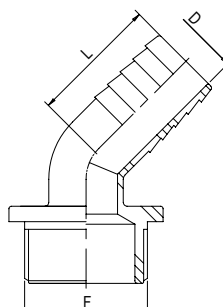

Part No.	F	D mm	L mm	Pack
8014300	1 1/4"	30	55	25
8014301		35	55	25
8014302		40	55	25
8014350	1 1/2"	30	55	25
8014351		35	55	25
8014352		40	60	25

- Raccorderia in polipropilene
- Polypropylene fittings
- Raccords en polypropylène

Raccordo portagomma diritto filetto maschio.

Hosetail male thread.

Raccord droit filetage mâle.

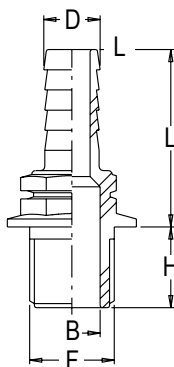

Part No.	F	B	D	H	L	Pack
		mm	mm	mm	mm	
8001101	3/8"	10	11	20	43	25
8001151	1/2"	14	13	20	44	25
8001152		14	15	20	44	25
8001153		14	19	20	49	25
8001154		14	22	20	48	25
8001201		18	13	22	46	25
8001202	3/4"	18	15	22	46	25
8001203		18	19	22	51	25
8001204		18	22	22	51	25
8001205		18	25	22	51	25
8001251		1"	25	19	22	53
8001252	25		25	22	53	25
8001253	25		30	22	60	25
8001254	25		32	22	63	25
8001301	1 1/4"	32	25	24	55	25
8001302		32	30	24	63	25
8001303		32	32	24	65	25
8001304		32	35	24	69	25
8001305		32	38	24	72	25
8001306		32	40	24	72	25
8001351	1 1/2"	38	40	24	72	25
8001352		38	45	24	75	25
8001353		38	50	24	78	25
8001401		2"	47,5	52	27	78

Raccordo portagomma curvo 90° filetto maschio.

90° hosetail - male thread.

Raccord coudé à 90° filetage mâle.

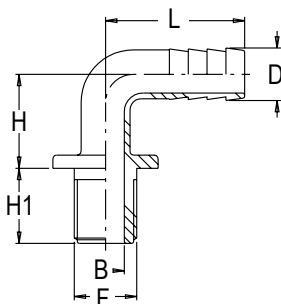

Part No.	F	B	D	H	L	H1	Pack
		mm	mm	mm	mm	mm	
8011101	3/8"	10	13	25	37	20	25
8011102		10	15	25	37	20	25
8011151	1/2"	14	13	25	37	20	25
8011152		14	15	25	37	20	25
8011153		14	19	25	37	20	25
8011154		14	13	25	37	27	25
8011155		14	15	25	37	27	25
8011156		14	19	25	37	27	25
8011201	3/4"	18	15	31	45	22	25
8011202		18	19	31	53	22	25
8011203		18	25	31	53	22	25
8011251	1"	25	25	31	53	22	25
8011252		25	30	31	60	22	25
8011253		25	32	31	60	22	25
8011301		1 1/4"	32	25	32	60	24
8011302	32		30	32	60	24	25
8011303	32		32	32	60	24	25
8011305	32		35	47	85	24	25
8011304	32		40	47	85	24	25
8011351	1 1/2"		38	30	47	80	24
8011352		38	32	47	80	24	25
8011353		38	35	47	80	24	25
8011354		38	38	47	80	24	25
8011355		38	40	47	85	24	25
8011401	2"	47,5	50	53	90	27	10
8011402		47,5	52	53	95	27	10

Raccordo portagomma diritto filetto femmina

Hosetail female thread

Raccord droit filetage femelle

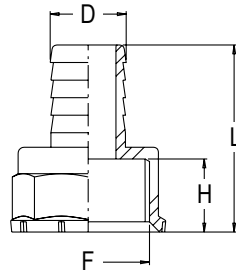

Part No.	F	D mm	H mm	L mm	Pack
8000151	1/2"	15	21	54	25
8000152		19	25	59	25
8000301	1"1/4	19	25	64	25
8000302		22	25	64	25
8000303		25	25	64	25
8000304		30	25	71	25
8000305		32	25	74	25
8000306	1"1/2	35	25	79	25
8000307		40	25	81	25
8000351		35	25	79	25
8000352	1"1/2	40	25	81	25
8000353		45	25	84	25
8000354		50	25	87	25
8000402	2"	50	28	90	10

Raccordo portagomma curvo 90° filetto femmina

90° hosetail female thread

Raccord coudé a 90° femelle

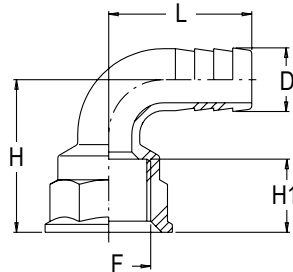

Part No.	F	D mm	H mm	L mm	H1 mm	Pack
8010201	3/4"	19	48	45	23	25
8010202		22	48	53	23	25
8010203		25	52	53	23	25
8010204		30	52	60	23	25
8010251	1"	30	62	60	23	25

Kit raccordo tutto un pezzo

Hosetail unit

Raccord complet

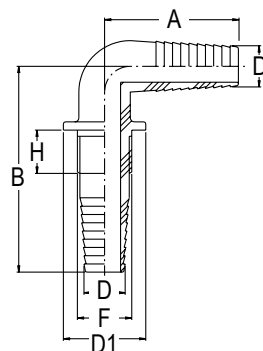

Part No.	F	H mm	D mm	D1 mm	A mm	B mm	Pack
8039151	1/2"	20	15-17	32	45	80	25
8039201	3/4"	21	20-24	40	65	100	25
8039251	1"	22	26-29	44	65	100	25

- Raccorderia in polipropilene
- Polypropylene fittings
- Raccords en polypropylène

Raccordo a gomito 90° filetti femmina.

90° elbow-female threads.

Raccord coudé à 90° filetages femelle.

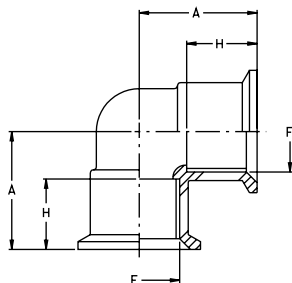

Part No.	F	H mm	A mm	Pack
8019151	1/2"	21	33,5	25
8019201	3/4"	23	38,5	25
8019251	1"	23	42,5	25
8019301	1"1/4	25	50	10
8019351	1"1/2	25	52,5	10
8019401	2"	28	62,5	10

Raccordo a gomito 90° filetti maschio-femmina.

90° elbow-male and female threads.

Raccord coudé à 90° filetages mâle/femelle.

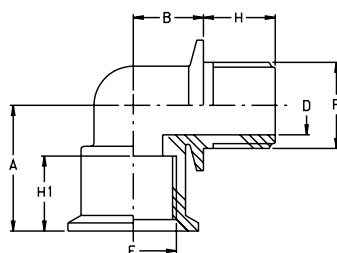

Part No.	F	D mm	H mm	H1 mm	A mm	B mm	Pack
8021151	1/2"	14	20	21	33,5	13,5	25
8021201	3/4"	18	22	23	38,5	21,5	25
8021251	1"	25	22	23	42,5	24,5	25
8021301	1"1/4	32	24	25	50	30	10
8021351	1"1/2	38	24	25	52,5	34	10
8021401	2"	47,5	27	28	62,5	67	10

Raccordo a gomito 90° filetti maschio.

90° elbow-male threads.

Raccord coudé à 90° filetages mâles.

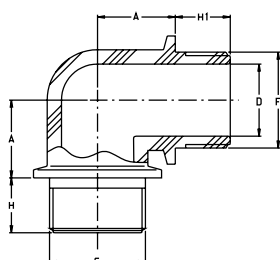

Part No.	F	H mm	H1 mm	A mm	D mm	Pack
8020251	1"	22	22	27	25	25
8020301	1"1/4	24	24	34	32	10
8020302	1"1/4	24	41	34	32	10
8020401	2"	27	27	44	47,5	10

Raccordo a "T" filetti femmina.

Female tee.

Raccord en "T" filetages femelle.

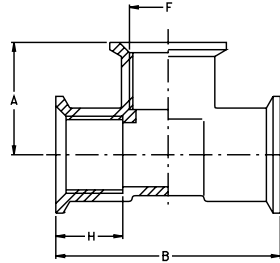

Part No.	F	H	A	B	Pack
		mm	mm	mm	
8026151	1/2"	21	67	33,5	25
8026201	3/4"	23	77	38,5	25
8026251	1"	23	85	42,5	10
8026301	1"1/4	25	100	50	10
8026351	1"1/2	25	105	52,5	5
8026401	2"	28	125	62,5	5

Raccordo a "T" filetti maschio.

Male tee.

Raccord en "T" filetages mâle.

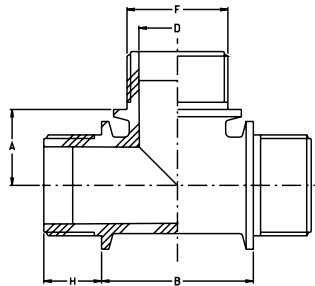

Part No.	F	H	A	B	D	Pack
		mm	mm	mm	mm	
8027301	1"1/4	24	111	55,5	32	10
8027351	1"1/2	24	118	59	38	5
8027401	2"	27	138	69	47,5	5

Raccordo a "T" filetti maschio - femmina.

Male and female tee.

Raccord en "T" filetages mâle/femelle.

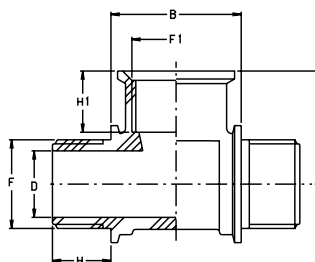

Part No.	F	F1	H	H1	D	A	B	Pack
			mm	mm	mm	mm	mm	
8028251	1"	1"	22	23	25	49	42,5	10
8028301	1"1/4	1" 1/4	24	25	32	60	50	10
8028351	1"1/2	1" 1/2	24	25	38	64	52,5	5
8028401	2"	2"	27	28	47,5	76	62,5	5

- Raccorderia in polipropilene
- Polypropylene fittings
- Raccords en polypropylène

Giunto filettato maschio

Male threaded connector

Joint fileté mâle

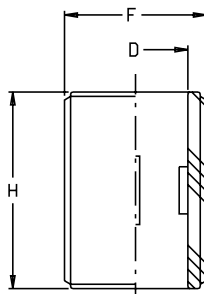

Part No.	F	D mm	H mm	Pack
8052201	3/4"	18	46	25
8052251	1"	25	46	25
8052301	1"1/4	32	50	25
8052351	1"1/2	38	50	10
8052401	2"	47,5	56	10

Niplo

Nipple

Nipple

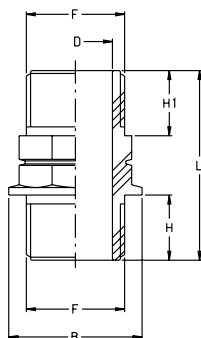

Part No.	F	B	H	D	L	H1	Pack
		mm	mm	mm	mm	mm	
8056151	1/2"	32	20	14	54	20	25
8056152		32	38	14	75	20	25
8056201	3/4"	40	22	18	60	22	25
8056202		40	48	18	86	22	25
8056251	1"	45	22	25	64	22	25
8056252		45	28	25	70	22	25
8056253		45	48	25	90	22	25
8056301	1"1/4	54,5	24	32	68	24	25
8056302		54,5	50	32	94	24	25
8056351	1"1/2	62	24	38	68	24	25
8056352		62	50	38	94	24	25
8056401	2"	72	27	47,5	74	27	10
8056402		72	50	47,5	97	27	10
8056451	2"1/2	80	31	63	79,5	31	10
8056501	3"	95	33,25	73,5	84,5	33,25	10

Niplo ridotto

Reducing nipple

Nipple double réduit

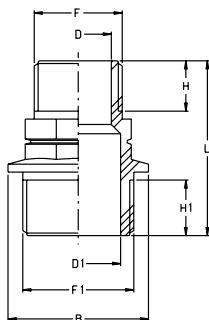

Part No.	F	B	H	D	F1	H1	D1	L	Pack
		mm	mm	mm	mm	mm	mm	mm	
8058101	3/8"	24	11,5	10	1/2"	15	14	38,5	25
8058151	1/2"	40	20	14	3/4"	22	18	58	25
8058152		44	20	14	1"	22	25	60	25
8058201	3/4"	44	22	18	1"	22	25	62	25
8058251	1"	53	22	25	1"1/4	24	32	66	25
8058301	1"1/4	60	24	32	1"1/2	24	38	68	25
8058351	1"1/2	72	24	38	2"	27	47,5	71	10
8058401	2"	80	26	47,5	2"1/2	31	63	75	10
8058451	2"1/2	95	31	63	3"	33	73,5	82	10
8058402	2"	95	33	47,5	3"	26	73,5	77	10

Riduzione maschio/femmina

Male and female reducer

Reducteur mâle/femelle

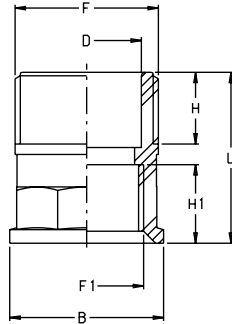

Part No.	FxF1	H mm	H1 mm	L mm	D mm	B mm	Pack
8059151	1/2" x 1/2"	20	21	44	14	32	25
8059202	3/4" x 1/2"	22	21	46	18	32	25
8059203	3/4" x 1"	22	23	48	18	44	25
8059204	3/4" x 1"1/4	22	25	51	18	53	25
8059251	1" x 3/4"	24	16,5	45	25	36	25
8059252	1" x 1"	22	23	48	25	44	25
8059253	1" x 1"1/4	22	25	51	25	53	25
8059301	1"1/4 x 1"	24	23	50	32	45	25
8059302	1"1/4 x 1"1/4	24	25	53	32	53	25
8059303	1"1/4 x 1"1/2	24	25	53	32	60	25
8059304	1"1/4 x 3/4"	21,5	16,5	47,5	32	46	25
8059351	1"1/2 x 1"1/4	24	25	53	38	53	10
8059352	1"1/2 x 1"	22,5	19,5	53,5	38	50	10
8059401	2" x 1"1/2	24	25	56	47,5	60	10
8059402	2" x 1"1/4	26	22	58,5	47,5	65	10
8059451	2"1/2 x 1"1/2	31	23,5	64,5	63	80	10
8059452	2"1/2 x 2"	31	23,5	71,25	63	80	10
8059501	3" x 2"	33	25,5	73	73,5	95	10
8059502	3" x 2"1/2	33	33	71,25	73,5	95	10

Manicotto ridotto

Reducing socket

Manchon réduit

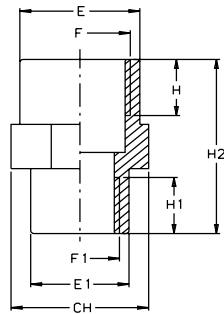

Part No.	FxF1	H mm	H1 mm	H2 mm	E mm	E1 mm	CH mm	Pack
8057101	1/2" x 3/8"	15,5	12	33,25	28	23	36	25
8057151	3/4" x 1/2"	16,5	15,5	38,25	34	28	36	25
8057201	1" x 3/4"	19,5	16,5	43	42	34	46	25
8057251	1"1/4 x 1"	22	20	49	51	42	55	25
8057301	1"1/2 x 1"1/4	23,5	22	50,5	58	51	65	25
8057351	2" x 1" 1/2	25	23,5	55	71,5	58	75	10
8057401	2"1/2 x 2"	33	25	66,5	88,5	71,5	95	10
8057451	3" x 2"1/2	36	33	73,5	102,5	88,5	105	10

Manicotto

Socket

Manchon

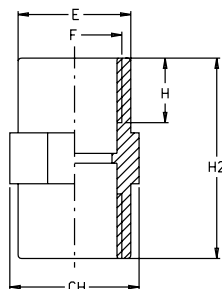

Part No.	F	H mm	L mm	E mm	CH mm	Pack
8054101	3/8"	12	30	23	30	25
8054151	1/2"	15,5	36,5	28	30	25
8054201	3/4"	16,5	39,5	34	36	25
8054251	1"	20	45,5	42	46	25
8054301	1"1/4	22	51	51	55	25
8054351	1"1/2	23,5	50,5	58	65	10
8054401	2"	25	59,5	71,5	75	10
8054451	2"1/2	33	70	88,5	95	10
8054501	3"	36	77	102,5	105	10

- Raccorderia in polipropilene
- Polypropylene fittings
- Raccords en polypropylène

Kit bocchettone di scarico



Complete tank outlet

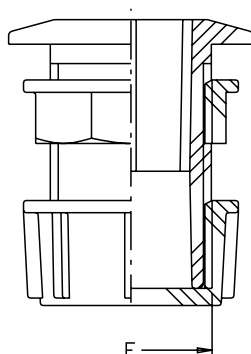

Kit goulotte de vidange

Part No.	F	Pack
8051151	1/2"	25
8051201	3/4"	25
8051251	1"	25
8051301	1"1/4 (long)	25
8051302	1"1/4 (short)	25
8051351	1"1/2	25
8051401	2"	10

Bocchettone di scarico



Tank outlet

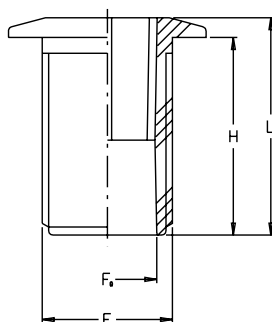

Goulotte de vidange

Part No.	F	H mm	L mm	Fo mm	Pack
8050151	1/2"	43,5	47	14	25
8050201	3/4"	43,5	48	18	25
8050251	1"	50	55	25	25
8050301	1"1/4	40	46	32	25
8050302	1"1/4	48	54	32	25
8050351	1"1/2	45	51	38	25
8050401	2"	64	71	47,5	10

Kit aspirazione antivortice con scarico antinquinante

Kit aspirazione antivortice con scarico antinquinante di nuova concezione permette di abbinare le funzioni di aspirazione pompa e di scarico cisterna nel rispetto delle vigenti norme CE.

Antivortex suction Kit with antipollution outlet

Antivortex suction kit with antipollution outlet of new conception combining 2 functions: the suction of pump and the emptying of the tank in conformity with E.E.C. directions.

Kit aspiration anti-tourbillon avec goulotte de vidange antipollution

Kit aspiration anti-tourbillon de nouvelle conception muni de goulotte de vidange antipollution. Il permet de combiner les fonctions d'aspiration de la pompe et de vidange citerne conformément aux dispositions CEE en vigueur.

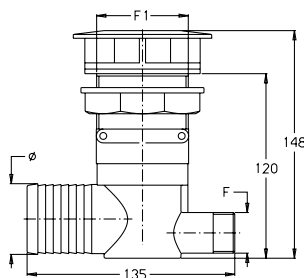

Part No.	Ø mm	F	F1	Pack
8209000	25			
8209001	30			
8209002	35	3/4"	2"	10
8209003	40			
8209004	45			

Girello



Fly nut

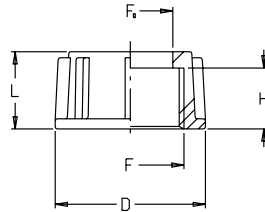

Écrou

Part No.	F	D	H	L	Fo	Pack
		mm	mm	mm	mm	
8040101	3/8"	26,5	14	18	13	25
8040151	1/2"	29	15	19	12,5	25
8040152	1/2"	29	15	19	15,5	25
8040202	3/4"	37	15	19	21,8	25
8040251	1"	44	18	21,5	27,3	25
8040301	1"1/4	55	18	21,5	35	25
8040351	1"1/2	63	18	22	41,5	25
8040401	2"	80	19	24	52,5	10

Ghiera



Back nut

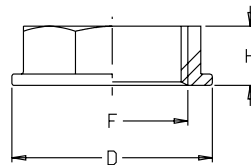

Embout

Part No.	F	D	H	Pack
		mm	mm	
8042101	3/8"	26,5	13	25
8042151	1/2"	29	13	25
8042201	3/4"	37	13	25
8042251	1"	44	13	25
8042301	1"1/4	55	15	25
8042351	1"1/2	63	15	25
8042401	2"	80	17	10
8042451	2"1/2	105	23	10
8042501	3"	125	26,5	10

Tappo filettato femmina



Threaded blanking cap

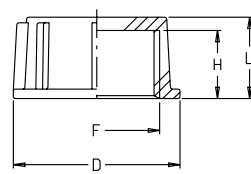

Bouchon fileté femelle

Part No.	F	D	H	L	Pack
		mm	mm	mm	
8044101	3/8"	26,5	14	18	25
8044151	1/2"	29	15	19	25
8044201	3/4"	37	15	19	25
8044251	1"	44	18	21,5	25
8044301	1"1/4	55	18	21,5	25
8044351	1"1/2	63	18	22	25
8044401	2"	80	19	24	10
NEW 8044401	2"1/2	92	20	24	10

Tappo filettato maschio



Threaded male plug

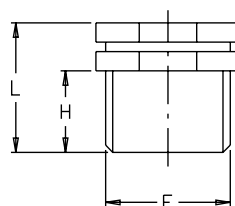

Bouchon fileté mâle

Part No.	F	H	L	Pack
		mm	mm	
8046051	1/4"	11	18	25
8046151	1/2"	15	23	25
8046201	3/4"	17	27	25
8046251	1"	19	31	25
8046301	1"1/4	22	34	25
8046351	1"1/2	24	36	25
8046401	2"	24	36	10
8046451	2"1/2	31	51	10
8046501	3"	33	57	10

- Raccorderia in polipropilene
- Polypropylene fittings
- Raccords en polypropylène

Accoppiatori con bloccaggio a camme

I nostri accoppiatori a camme sono realizzati in polipropilene rinforzato con fibra di vetro per garantire ottima resistenza agli agenti chimici e massima durata. Leve di bloccaggio, anelli e spinotti sono in acciaio inossidabile.

Tutti i nostri accoppiatori a camme sono intercambiabili ai prodotti realizzati dai principali costruttori mondiali.

- Filettature NPT a richiesta.

- Guarnizioni di tenuta standard in NBR.

Cam lever couplings

Our comprehensive range of cam lever couplings are made from glass reinforced polypropylene for strength and durability, featuring stainless

steel arms, pins and rings.

They are interchangeable with other couplers and adapters.

- NPT threads on demand.

- NBR standard gaskets

Raccords rapides a cammes

Tous nos raccords rapides sont fabriqués en polypropylène renforcé par fibres de verre avec parties métalliques en acier inoxydable afin de garantir une fiabilité et une durée optimale.

Tous nos raccords sont compatibles avec les produits des principaux fabricants.

- Filetage NPT sur demande.

- Joints en: NBR.



Adattatore maschio » Filetto femmina

Male adapter » Female thread

Adaptateur mâle » Filet femelle

A



Part No.	Size	F	Pack
8034201	3/4"	G 3/4"	25
8034251	1"	G 1"	25
8034301	1"1/4	G 1"1/4	25
8034351	1"1/2	G 1"1/2	25
8034401	2"	G 2"	25
8034501	3"	G 3"	10

Accoppiatore femmina » Filetto maschio.

Female coupler » Male thread

Coupleur femelle » Filet mâle

B



Part No.	Size	F	Pack
8034202	3/4"	G 3/4"	25
8034252	1"	G 1"	25
8034302	1"1/4	G 1"1/4	25
8034352	1"1/2	G 1"1/2	25
8034402	2"	G 2"	25
8034502	3"	G 3"	10

Accoppiatore femmina » Portagomma

Female coupler » Hosetail

Coupleur femelle » Portetuyau

C



Part No.	Size	Ø mm	Pack
8034203	3/4"	19	25
8034253	1"	25	25
8034304	1"1/4	32	25
8034354	1"1/2	38	25
8034403	2"	50	25
8034503	3"	75	10

Accoppiatore femina » Filetto femmina.

Female coupler » Female thread

Coupleur femelle » Filet femelle.

D



Part No.	Size	F1	Pack
8034204	3/4"	G 3/4"	25
8034254	1"	G 1"	25
8034305	1"1/4	G 1"1/4	25
8034355	1"1/2	G 1"1/2	25
8034404	2"	G 2"	25
8034504	3"	G 3"	10

Adattatore maschio » Portagomma.

Male adapter » Hosetail

Adapteur mâle » Portetuyau

E



Part No.	Size	Ø mm	Pack
8034205	3/4"	19	25
8034255	1"	25	25
8034307	1"1/4	32	25
8034357	1"1/2	38	25
8034405	2"	50	25
8034505	3"	75	10

Adattatore maschio » Filetto maschio.

Male adapter » Male thread

Adapteur mâle » Filet mâle

F



Part No.	Size	F1	Pack
8034206	3/4"	G 3/4"	25
8034256	1"	G 1"	25
8034308	1"1/4	G 1"1/4	25
8034358	1"1/2	G 1"1/2	25
8034406	2"	G 2"	25
8034506	3"	G 3"	10

H

Tappo per adattatore maschio
Cap for male adapter
Bouchon adapteur mâle



Part No.	Size	Pack
8034207	3/4"	25
8034257	1"	25
8034309	1"1/4	25
8034359	1"1/2	25
8034407	2"	25
8034507	3"	10

G

Tappo per accoppiatore femina
Cap for female coupler
Bouchon pour coupleur femelle



Part No.	Size	Pack
8034208	3/4"	25
8034258	1"	25
8034310	1"1/4	25
8034360	1"1/2	25
8034408	2"	25
8034508	3"	10

- Raccorderia in polipropilene
- Polypropylene fittings
- Raccords en polypropylène

Raccordo portagomma a "T"



Tee hosetail

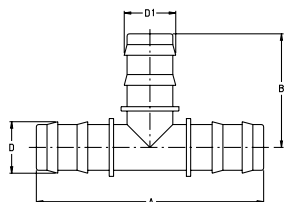

Raccord en "T"

Part No.	D mm	D1 mm	A mm	B mm	Pack
8025000	16	16	68	34	100
8025001	20	20	59	44	100
8025002	25	25	106	47	100
8025003	25	32	110	49	100
8025004	32	32	130	49	100
8025005	40	40	140	68	50

Raccordo a "Y"



"Y" fitting

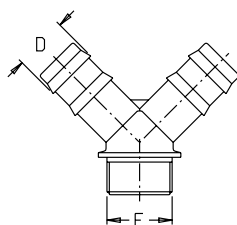

Raccord en "Y"

Part No.	F	D mm	Pack
8031000	3/4"	15	100
8031001	3/4"	25	25
8031002	1"	25	25
8031003	1"	30	25
8031004	1"1/4	30	25

Raccordo portagomma diritto di giunzione



Hosetail connector

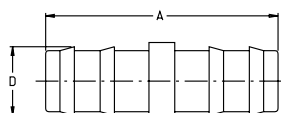

Raccord porte-tuyau

Part No.	D mm	A mm	Pack
8004000	16	59	100
8004001	20	68	100
8004002	25	73	100
8004004	32	73	100
8004003	36	87	50

Raccordo a "T" filetti maschio per raccordi a battuta piana



Male tee for flat seat fittings

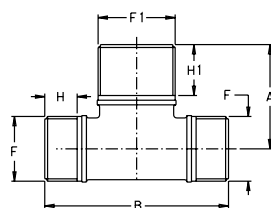

Raccord en "T" filetages mâle pour raccords avec siège plat

Part No.	F	F1	H mm	H1 mm	A mm	B mm	Pack
8027151	1/2"	1/2"	15	15	34	68	50
8027152	1/2"	3/4"	15	16,5	35	68	50
8027201	3/4"	3/4"	16,5	16,5	35	71	50
8027202	3/4"	1"	16,5	17	43	71	50
8027251	1"	1"	17	17	43	86	25
8027252	1"	1"1/4	17	19,5	51	86	25

Guarnizioni O-Rings per raccorderia con filetto femmina

O-Ring gaskets for fittings with female thread

Joints toriques pour raccords filetage femelle

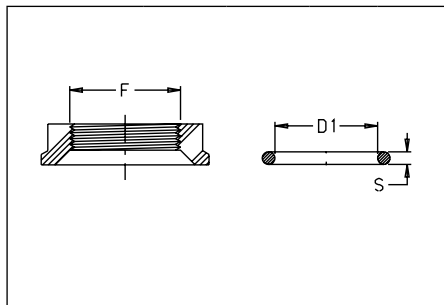

Part No.	F	D1 mm	S mm	Pack
G00001018	G1/2"	20,24	2,62	50
G00001020	G3/4"	25,07	2,62	50
G00001026	G1"	29,82	2,62	50
G00001046	G1"1/4	39,69	3,53	50
G00001048	G1"1/2	47,22	3,53	50
G00001052	G2"	58,74	3,53	50

Guarnizioni O-Rings per raccorderia con girello

O-Ring gaskets for fittings with fly nut

Joints toriques pour raccords avec écrou

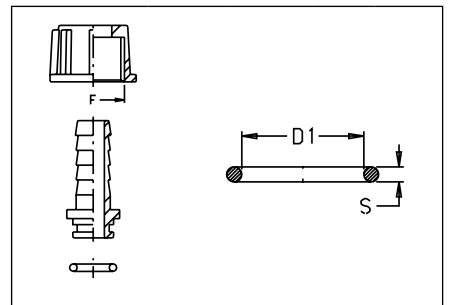

Part No.	F	D1 mm	S mm	Pack
G00001002	G1/2"	10,5	2	50
G00001012	G3/4"	13,1	2,62	50
G00001018	G1"	20,24	2,62	50
G00001022	G1"1/4	26,65	2,62	50
G00001028	G1"1/2	32,99	2,62	50
G00001030	G2"	39,34	2,62	50

Guarnizioni per raccorderia a sede piana con girello

Gaskets for flat seat fittings with fly nut

Joints pour raccords à siège plat avec écrou

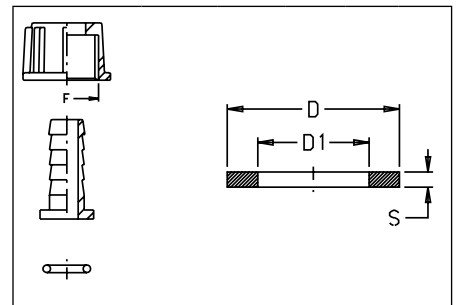

Part No.	F	D mm	D1 mm	S mm	Pack
G00002000	G3/8"	14	10	2,5	50
G00002002	G1/2"	19,2	11,5	2,5	50
G00002004	G3/4"	24,5	17	2,5	50
G00002006	G1"	30,7	20	2,5	50
G00002010	G1"1/4	39,5	27,5	2,5	50

Guarnizioni per tappi con filetto femmina.

Gaskets for threaded blanking cap.

Joints pour bouchons filetage femelle.

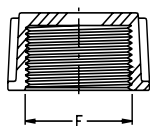

Part No.	F	D mm	D1 mm	S mm	Pack
G00001010	G 3/8"	-	11,19	2,62	50
G00001014	G1/2"	-	13,95	2,62	50
G00002004	G3/4"	24,5	17	2,5	50
G00002006	G1"	30,7	20	2,5	50
G00002010	G1"1/4	39,5	27,5	2,5	50
G00002012	G1"1/2	45	33	3	50
G00002014	G2"	60	40	4	50

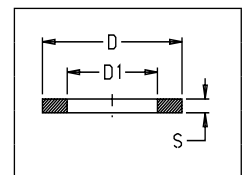
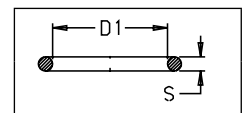

Guarnizioni piane per raccorderia a parete con filetto maschio.

Flat gaskets for wall fittings with male thread.

Joints toriques pour raccord mural filetage mâle.

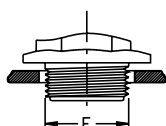

Part No.	F	D mm	D1 mm	S mm	Pack
G00002044	G1/4"	20	13	3	50
G00002004	G3/8"	24,5	17	2,5	50
G00002008	G1/2"	33	21	2,5	50
G00002010	G3/4"	39,5	27,5	2,5	50
G00002012	G1"	45	33	3	50
G00002014	G1"1/4	60	40	4	50
G00002016	G1"1/2	67	47	3	50
G00002018	G2"	84	59	4	50
G00002045	G2"1/2	94,5	76	3,5	50
G00002040	G3"	110	90	3,5	50

